

Rebag-Ware: Reputation-based Governance of Public Works

Roberto CONFALONIERI¹, Cristiano LEONI², Lucio PICCI³

¹*Departament de Llenguatges i Sistemes Informatics.*

*Universitat Politecnica de Catalunya. c/ Jordi Girona 1-3. E08034 Barcelona, Spain,
Tel: +39-051-20926, Fax: +39-051-2092664, Email: roberto.confalonieri@ei.unibo.it*

²*Tek Tank, – <http://www.tektank.it>, University of Bologna, Via dei Bersaglieri 4, 40125,
Bologna, Italy, Tel: +39-051-20926, Fax: +39-051-2092664, Email:
cristiano.leoni@unibo.it*

³*Tek Tank, – <http://www.tektank.it>, University of Bologna, Via dei Bersaglieri 4, 40125,
Bologna, Italy, Tel: +39-051-2092608, Fax: +39-051-2092664, Email:
lucio.picci@unibo.it*

Abstract: Reputation-based Governance (Rebag) is a framework to address governance problems that hinges on the reputation of the relevant actors. It functions thanks to an appropriate Web-based information system that encompasses the concept of Internet-based Reputation System, of which eBay represents an example. Rebag-Ware is a demonstrator of such an information system, showing an application of the proposed governance model to the management of public works.

Rebag provides strong incentives to the actors of governance to behave efficiently and honestly. It allows for the computation of routine statistics that are used to fight corruption. Also, it allows for very advanced forms of public involvement that include participative planning and budgeting.

In the paper, Rebag-Ware 1.0 is used to show some of the characteristics of the proposed model of governance. The site of the project is <http://www.rebag.it>. Rebag-Ware can be accessed at: <http://fire.ei.unibo.it:8080/rebagware/>

Keywords: Rebag, Reputation-based Governance, Reputation, Trust, Confidence, Public works, Rent-seeking, Corruption, Transparency, Accountability, Web-based Information System

1. 1. Introduction

Reputation-based Governance (from now on, Rebag) is a framework to address governance issues that hinges on the reputation of the actors involved. In principle, Rebag can be applied both to the public and the private sector. Emphasis is placed here on public governance and, more to the point, on the management of "policies". Policies can be either "projects", i.e., initiatives having a goal well specified in advance (such as, the building of a bridge), or "programs", i.e., services that are delivered over a period of time (for example, an educational degree by a public university).

The desire to build and to maintain a good reputation is a powerful tool to ensure that collective action delivers socially desirable results. Individuals and organizations valuing their reputation have an incentive to behave well, in order not to squander what amounts to a costly investment for the future. Implicit in private calculations on what course of action to take, there is a weighting between the short-term gain to be obtained from a dishonest or

predatory behaviour, and the long-term loss that follows from losing the trust of others. The more important is one's reputation, the higher is the chance that the balance tilts in favour of virtuous behaviours, benefiting both individuals and society as a whole.

Reputation not only helps in eliciting honest behaviours from agents that, somehow cynically, decide how to behave only considering their self-interest. Very often, the quality of a product becomes fully known after its delivery has taken place and, sometimes, only after its prolonged use. Quality is influenced both by the effort exerted and by skill. Producers with differing skills may be able to deliver undistinguishable promises for product delivery; their past performances, however, may allow to discriminate between high and low quality suppliers. When this happens, market selection forces are set in motion that weed out the least fit from the competition. Uncompetitive firms would lose importance and, eventually, go out of business, and mediocre bureaucrats would find it hard to obtain a promotion.

Reputation considerations, in fact, already play a significant role in most real-life governance contexts. The relevance of reputation considerations in explaining human interactions surely dates to the early days of the human experience, and a series of classic works in economic history, for example, elegantly explains how reputation considerations were of paramount importance in determining trading in the middle ages (see [7], [8] and [9]). Rebag innovates with respect to past and current practices because it provides a coherent governance framework where reputational considerations are at the center of governance, thanks to a structured monitoring and assessing of policies' outcomes, that for the most is carried out by the very people who are affected by the policies. For example, the end users of a public building such as a school - the local community where it is located, the teachers, etc. - would be able to voice their opinions, contributing to the formation of the reputations of the firm that built the school. Reputations, in turn, influence the allocation of resources and of power. Keeping track of policies, and systematically assessing their outcomes, produces a governance landscape characterized by an unprecedented level of transparency and of accountability.

Within Rebag, the assessments of the outcomes of policies are procedurized and are coded into an appropriate Web-based information system. While the Internet, in general, is not needed for a governance method to be influenced by reputational considerations, the availability of an appropriate Internet-based informational infrastructure is an integral part of Reputation-based Governance. We call such an infrastructure Rebag-Ware.

The nature of the information system reminds of a very popular site, eBay (www.ebay.com). On eBay, both sellers and buyers have an incentive to be honest because they are subject to the evaluation of their business counterpart: a seller receiving many negative comments from previous buyers would find it difficult to stay on the market, and a buyer in the same predicament would have a hard time doing his shopping. Fear of acquiring a bad reputation represents a strong incentive favouring virtuous behaviour, and the observed equilibrium on eBay is one where most people correctly describe the merchandise that they plan to sell, efficiently ship it, and pay their bills. eBay is a well studied example of the more general concept of "Internet-based Reputation System" (IBRS) (see [5] and [4]). With respect to IBRSs, Rebag represents a broader framework and concept, because it addresses public governance from a very general point of view, and because it has several broad implications, some of which we briefly consider.

We focus on the application of Rebag to the management of public works. Public works add to the stock of infrastructure available to an economy, their relevance of public infrastructure as a determinant of economic development and growth being amply documented by a strand of empirical literature initiated by Aschauer (see [1]). Building infrastructure effectively, efficiently, and honestly, proves to be difficult. Particularly in less developed countries, resources dedicated to the construction of public infrastructure are

often wasted, resulting in corruption or in plain inefficiencies. The paramount relevance of the problem, both in developing and in developed countries, is a compelling motivation for the present work.

The structure of the paper is as follows. In the next section we describe Rebag-Ware, a demonstrator of a Web-based information system for the management of public works. In Section 3 we discuss a series of implications of Reputation-based Governance, and indicate how these drive our agenda for further research and development of Rebag-Ware. Last, the conclusions follow.

2. Rebag-Ware and the governance of public works

2.1 – The information system supporting Rebag

At the basis of Rebag-Ware there is a taxonomy of possible projects. For example, public works may be “roads”, “bridges”, “buildings”, etc. Within each type of good, there are further sub-classes: Buildings may be schools, police headquarters, and so forth. All projects are included in a database accessible by all. In the current version of Rebag-Ware, the public administration that is in charge of a given project is responsible for its inclusion upon its formal approval into the database.

Project's details for Nuova vicinale Cusercoli-Bertinoro

Id: P169
Description: Nuova vicinale Cusercoli-Bertinoro
Supplementary Documentation : [Project's supplementary Documentation](#)
Project's cost: € 8.500.000
Category: Roads
Type of Good: local roads
Status of the works: Completed
Work Breakdown Structure (WBS):

- **Deliverable 1:** Lavori di scavo - Tratta 1
- **Deliverable 2:** Lavori di scavo - Tratta 2
- **Deliverable 3:** Lavori di scavo - Tratta 3
- **Deliverable 4:** Costruzione strada
- **Deliverable 5:** Asfaltatura

Time line:

- Start Date, actual: 1-Feb-05
- End Date, actual: 1-Dec-05

Administrations (and their Departments) executing the Project, and relative share :

- **Provincia di Forli-Cesena:** 55%
 - *dipartimento Prov-FC-A:* 55%
- **Comune di Meldola:** 14%
 - *dipartimento Meldola-A:* 14%
- **Comune di Bertinoro:** 13%
 - *dipartimento Bertinoro-A:* 13%
- **Comune di Cusercoli:** 18%
 - *dipartimento Cusercoli-A:* 18%

Contributing Firms, and relative share:

- **Asfalti e c.:** 14%
- **Works:** 18%
- **Strade & Ponti:** 27%
- **Grandi lavori:** 41%

Figure 1 - Summary page of a complex project

The best way to get acquainted with the system is by accessing it using one of the provided user identification. In this way, it is possible to impersonate one of the actors of governance - a citizen, an administrator, or the representative of a contracting firm – and experiment Rebag within a realistic scenario. Rebag-Ware is at <http://fire.ei.unibo.it:8080/rebagware/> The examples that we illustrate below are all based on imaginary data, relating to public works in the area of the northern Italian city of Forlì. In particular, we assume that there are 20 projects, affecting a total of 50 persons, and carried out by 10 administrations and 15 firms.

Upon identification by the system, each actor accesses a list of public works . Preliminary information about a project include its general description according to the codified taxonomy (type of good, location, expected cost, etc.), technical drawings, and any documentation that may accompany the early stages of the project, such as an environmental impact and a cost-benefit analysis. As the project evolves, more information is provided, eventually to include details on costs and on the final outcome, comprising, for instance, pictures of the completed works.

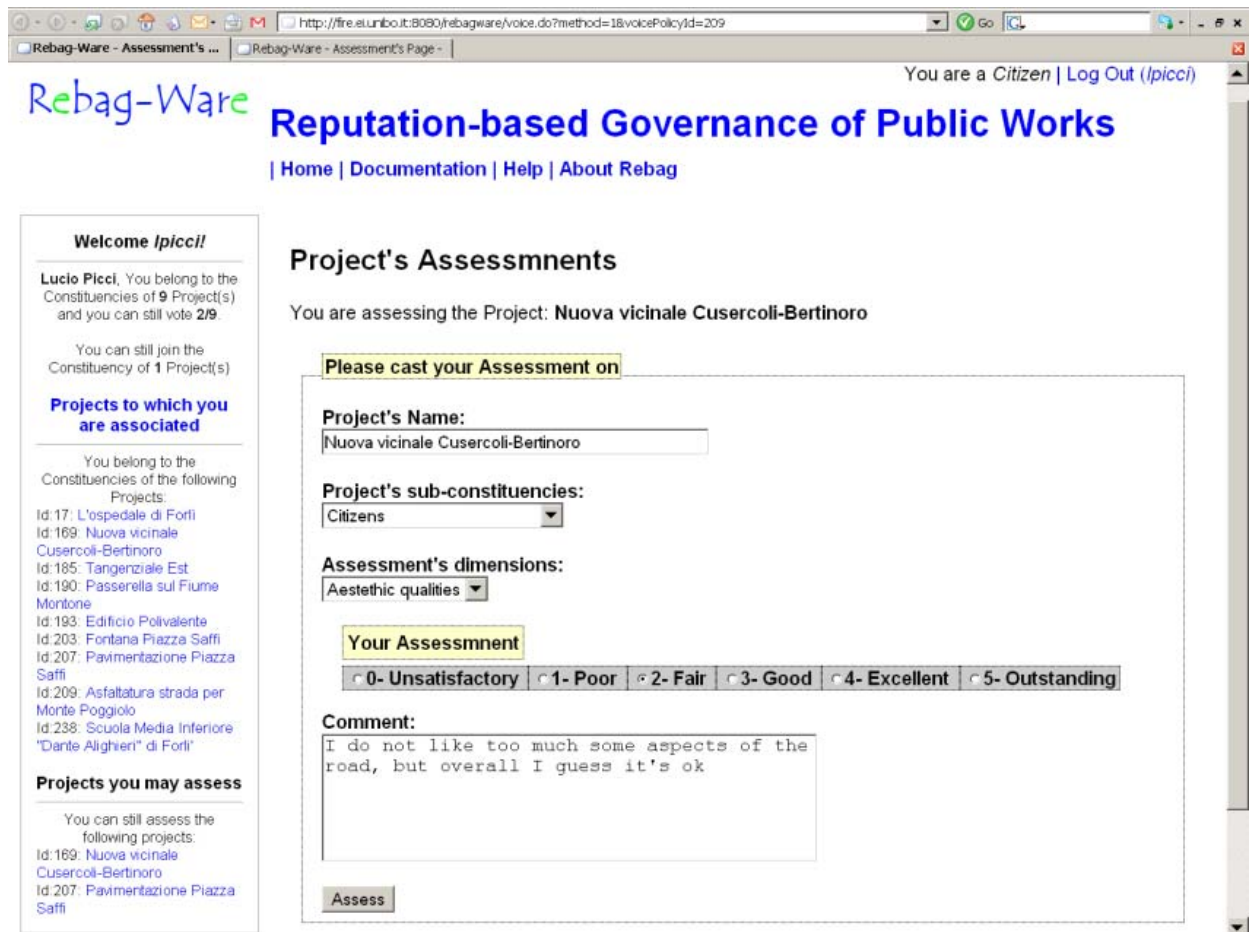

Figure 2 - Citizen's assessment page

Each project is associated with the administration and with the contracting firms that are responsible for its execution. In particular, the responsibilities of, and the compensations to, the contracting firms are recorded, and the information system keeps track of all the projects executed by each administration and by each firm. All lists can be navigated so that it is straightforward to move, say, from the page illustrated in Figure 1, to a summary page for each of the administration involved, indicating all their projects, and to analogous pages for contracting firms. As an example, Figure 1 shows part of the summary page of a fairly complex project run jointly by 4 administrations with the help of 4 firms.

The outcome of a project is assessed by a set of relevant actors. Public administrators in charge of a project express their opinion on the quality of the work carried out by the contracting firms. Firms assess the managerial skills of public administrations. The people judge the public works affecting them. Such opinions are highly structured, and refer to a small set of well defined characteristics. For example, the public could judge the “aesthetic qualities”, “usefulness” and “accessibility” of a given completed project. An example is provided in Figure 2, showing how a citizen may assess a complex project. Each citizen (administration, firm) is allowed to vote only once for a given project, and currently all votes are allowed to be in the range 0 (very bad)-5 (very good) . To each vote, it is possible to associate a comment.

Summary views of the past record of individual administrations are easily accessed. In particular, a page contains a list of all the projects carried out by a given administration, and the same happens for firms, whose past projects can be easily accessed. The assessments on the quality of completed public works are aggregated appropriately and made public. They reverberate to administrations, administrators, and firms, and are used to compute their reputations.

2.2 – The architecture of Rebag-Ware

Detailed technical information on Rebag-Ware are available at the official site of the project (<http://www.rebag.it>). We here provide a very brief overview of its architecture.

Rebag-Ware has been realized as a Java Web application following the Model-View-Controller (MVC) paradigm . MVC is an architectural design pattern where (interactive) applications are organized into three distinct components: the application *Model* for its data representation and business logic; the *View*, to provide data presentation and user input; the *Controller* to dispatch requests and control flow. The MVC philosophy has several benefits (see [11] and [17]). In particular, separating responsibilities among model, view, and controller objects reduces code duplication and allows for modular and flexible applications. Figure 3 shows the MVC paradigm in Java.

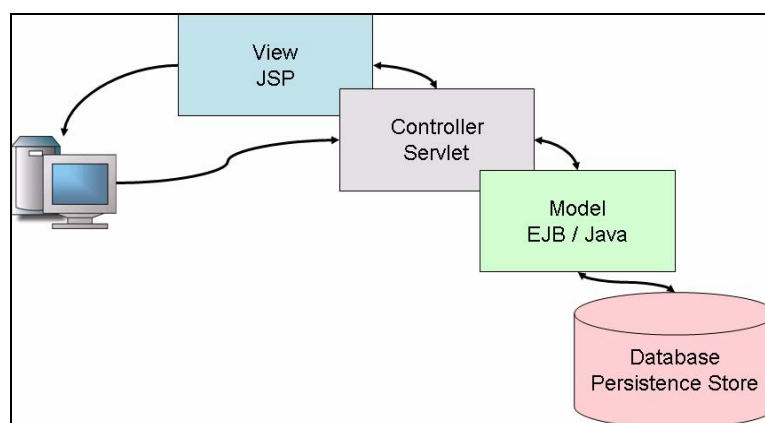

Figure 3 - The MVC paradigm in Java

Figure 4 illustrates how Rebag-Ware interprets the MVC paradigm. Users such as Administrations, Firms and Citizens interact with the system through a Web-based interface, generated by the View layer. User requests are dispatched to the Controller servlets that handle the flow of the application. These servlets use the classes belonging to the Rebag-Ware Model, interacting with the database and eventually forwarding data to the View Layer, that generates a response page to be sent back to the user.

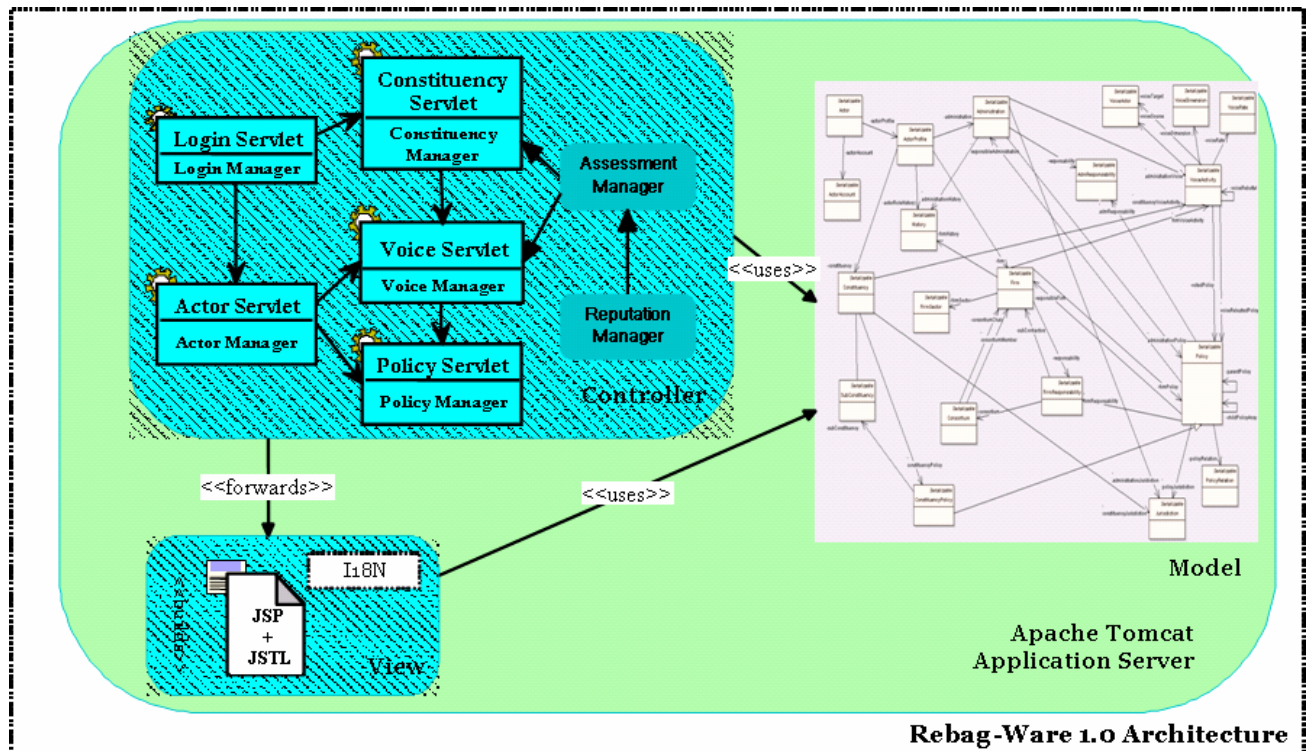

Figure 4 - The Architecture of Rebag-Ware

2.3 Application issues

The current version of Rebag-Ware is a demonstrator that is being used both to obtain realistic indications on the characteristics of Reputation-based Governance, and to illustrate the concept to prospective partners in the research project and to prospective adopters. A few public administrations in Italy have already formally expressed their interest.

From a technological point of view, the current version of Rebag-Ware is engineered in such a way as to be prone, with further development, to admit real life applications within a single policy domain – such as the one presented here. An interesting issue would be to develop Rebag-Ware according to a distributed architecture, to allow for the integrated adoption by more public administrations, each one administering a part of an overall information system. Currently there are no plans to proceed in that direction, but the issue could be dealt with once appropriate financial resources are secured.

2.4 The governance of public works

Reputation-based governance of public works establishes a number of incentives and of disincentives. The general public can access detailed information on public works. Dedicated views of the data would rank the evaluations of projects, by type and possibly by geographic location, and the reputations of firms, administrations and administrators. Similar summaries are generated for administrations and firms. An example is provided in Figure 5, showing a list of administrations ranked according to their reputation.

By themselves, such public rankings would put a premium on honest and efficient behaviour by public administrations, considering that they would influence electoral choices. Also, bureaucrats would be pressured not to be looked down by their peers. Moreover, if a firm is active in both the public and in the private sector, a good reputation in the former would be expendable in the latter. Such effects could then be made more cogent by deliberate publicity initiatives, such as the publishing in newspapers the “ten best

(worst) projects” of the year. The media also would play a role in providing incentives, since journalists, by accessing Rebag-Ware, would have a very powerful tool at their fingertip, to research and to expose both worst and best practices.

Moreover, reputation considerations could be employed within source selection procedures, as it happens today in the United States (see [10]). Note however that reputation-based governance of public works, thanks to its strong incentives, would make more attractive allocation mechanisms based on off-the-shelf purchases, instead than on competitive biddings, an evolution of procurement systems already hinted at in [14].

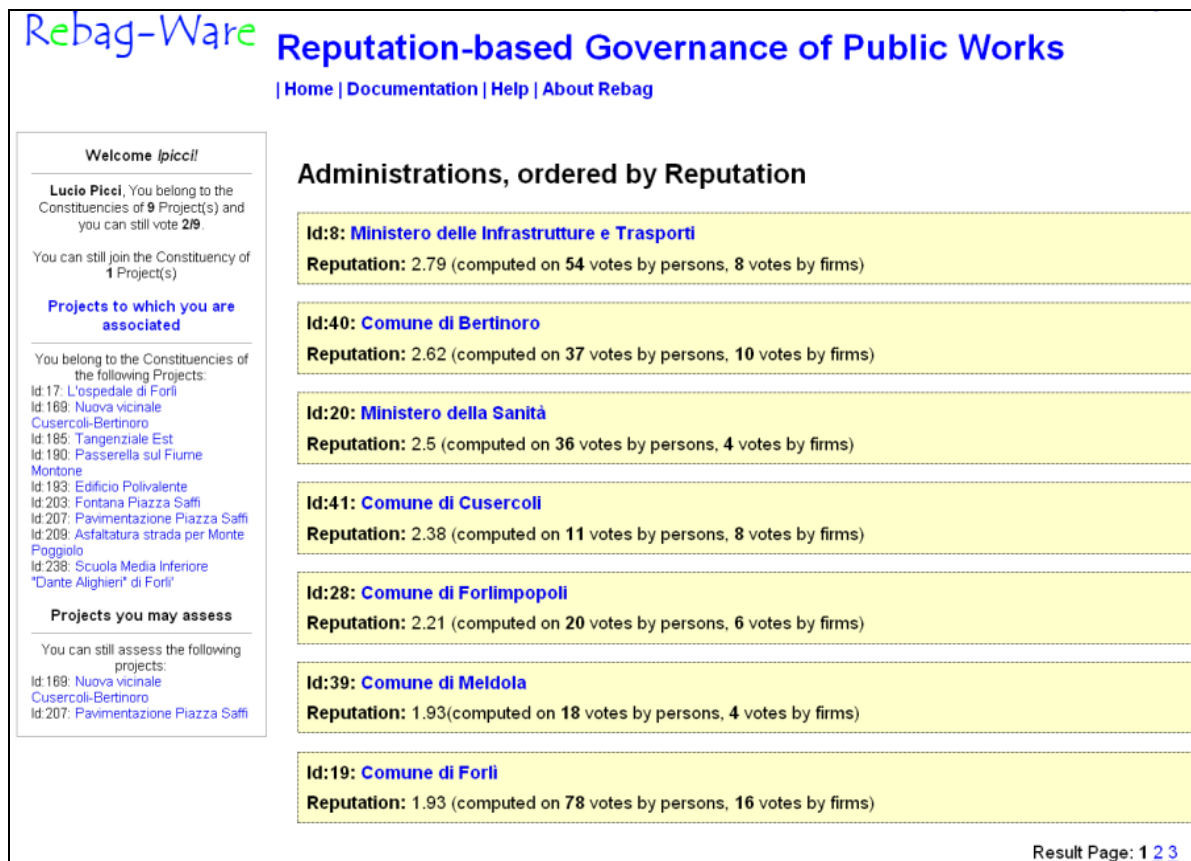

Figure 5 - Administrations ranked by reputation

3. Discussion and further developments

3.1 The "integrated" production of statistics

Rebag-Ware routinely produces a series of statistics that are generated as views of the underlying database. When all the relevant information on public works are contained in a digital repository, computing summary statistics of interest does not require any ad hoc data gathering and processing, because it can be done in an "integrated" fashion by producing a "view" of the available data. As argued in [12], this is an important departure with respect to how official statistics are produced today.

The availability of information on many projects would allow for the computation of rankings of individual projects on several dimensions. Summary statistics would be available also for various subsets of the data, providing views by geographic unit, by type of administration and by contracting firm. We are planning to include several examples of such statistics in the next version of Rebag-Ware.

3.2 Rebag and the fight against corruption

Public corruption is detrimental to economic and societal well-being, by subtracting valuable resources from productive ends and by tilting private choices towards the pursuit of unproductive activities. The damages of corruption only in part derive from its immediate drain of public resources: more importantly, corruption has distortionary effects on both private and public choices. While public corruption is present everywhere in the world, available data show that corruption is a particularly severe problem in less developed countries and in former socialist countries (see [16]).

There is a broad agreement on the fact that transparency is an important antidote against corruption. For example, in a known case, the reporting in Kenyan newspapers of the amount of transfers to local schools was instrumental in reducing the siphoning-off of those moneys to private pockets (see [15]). Reputation-based governance represents a unified framework to sharply increase transparency and to provide incentives favouring honest behaviour. It allows for the computation of “integrated” statistics that provide long sought-for objective measures of governance, such as the one in [6], that are a prerequisite for the necessary monitoring activities to fight corruption.

3.3 Rebag and participative planning and budgeting

Projects of public works are inserted into the present version of Rebag-Ware upon their formal approval. In principle, the information system could also admit the possibility of inserting competing proposals for a given piece of infrastructure, so that the people could express their opinion and contribute to the decision making process, together with their elected officials, according to a specified participative process. The citizens could also be allowed not only to contribute in selecting one alternative among a given set, but also, to propose their own policy, or policy design, possibly by accessing a collaborative on-line environment.

In a context where the prevailing form of governance is reputation-based, the entire budget of a public administration would amount to the sum of the outlays for all its projects and programs. Rebag-Ware could then model a process where citizens not only participate in the selection (and, eventually, design) of a given policy, but also, they contribute to the allocation of the budget to alternative ends. In this sense, Reputation-based Governance also provides a coherent framework to treat participative design and participative budgeting initiatives, where participation goes hand in hand with the accountability of the actors of governance.

4. Conclusions

There is a broad consensus on the fact that accountability and transparency are essential prerequisites for good governance. Also, there is a clear understanding that Internet-based technologies can play a key role in facilitating both, given their capabilities of cheaply publishing structured information on the behaviours that are relevant for governance, and in allowing the people affected by policies to voice their opinions. We have argued that Reputation-based Governance provides a coherent framework to address these issues. Rebag-Ware, the Web-based infrastructure currently dedicated to the management of public works, already illustrates in practice several features of the desired governance model.

One goal of the current research effort is to reach an adequate understanding of the many implications of Rebag. Due to space constraints, only a few of these implications have been hinted at in the paper, and the interested reader is referred to [12] and [13] for

their thorough treatment. The project also has a normative character, that is, we argue that reputation-based governance would be a good thing to have. However, adopting new governance models and new technologies is a lengthy process, particularly when the changes, as in the present case, would be radical in several respects. Developing Rebag-Ware for a particular policy domain was needed both to allow for practical experimentation of its potentialities, that in turn feed back on the analytical research activity, and to present the idea to prospective future partners in this exciting project.

5. References

- [1] Aschauer, David (1989), "Is Public Expenditure Productive?", *Journal of Monetary Economics*, vol. 23, pp. 177-200.
- [2] Bajari, Patrick L., McMillan, Robert S., and Steve Tadelis, 2003, Auctions versus negotiations in procurement: an empirical analysis, NBER Working Paper 9757.
- [3] Cabral, Luis (2005) *The Economics of Reputation and Trust*, mimeo
- [4] Cabral L. - Hortaçsu A., (2006) "The Dynamics of Seller Reputation: Evidence from eBay", mimeo.
- [5] Dellarocas, Chrysanthos, 2003, The Digitalization of Word of Mouth: Promise and Challenge of Online Feedback Mechanisms, *Management Science*, Vol. 49, No. 10, pp. 1407-1424.
- [6] Golden, Miriam and Lucio Picci, 2005, Proposal for a New Measure of Corruption Illustrated Using Italian Data, *Economics and Politics*, Vol. 17, n. 1, pp. 37-75.
- [7] Greif, Avner, 1989, Reputation and Coalitions in medieval Trade: Evidence on the Maghribi Traders, *The Journal of Economic History*, Vol. 49, No. 4 (Dec. 1989), pp. 857-882.
- [8] Greif, Avner, 1993, Contract Enforceability and Economic Institutions in Early Trade: The Maghribi Traders' Coalition. *American Economic Review* 83, pp. 525-548.
- [9] Greif, Avner, Paul Milgrom and Barry R. Weingast, 1994, Coordination, Commitment, and enforcement: The Case of the Merchant Guild, *The Journal of Political Economy*, Vol. 102, N. 4, pp. 745-776.
- [10] Kelman, Steven (2002), Remaking Federal Procurement, *Public Contracts law Journal*, Summer
- [11] Johnson, Ralph E. (1997) "Frameworks=(components + patterns)", *Communications of the ACM*, vol. 40, no. 10, pp. 10-17
- [12] Picci, Lucio (2007a), Reputation-based Governance of Public Works, in G. Piga and Khi V. Thai, *Economics of Public Procurement*, Palgrave.
- [13] Picci, Lucio (2007b), Reputation-Based Governance, mimeo, work in progress.
- [14] Rose-Ackerman, Susan (2005) The Challenge of Poor Governance and Corruption, Copenhagen Consensus Challenge Paper, *Revista DireitoGV*, Special Issue 1, pp. 207-266, November.
- [15] Svensson, Jacob (2005), Eight Questions about Corruption, *Journal of Economic Perspectives*, Vol. 19, N. 3, 19-42.
- [16] Transparency International, 2006, The Corruption Perception Index, available on-line at: http://www.transparency.org/policy_research/surveys_indices/cpi
- [17] Veit, Matthias and Herrmann, Stephan (2003), Model-View-Controller and Object Teams: A Perfect Match of Paradigms, presented at the 2nd International Conference on Aspect-Oriented Software Development, March, Boston